



Tape Solutions for Transportation Vehicles



Tape Solutions for Transportation Vehicles

Saint-Gobain[®], a leader in the automotive and transportation markets, provides attachment and sealing tapes that solve for the specific needs of transportation vehicle applications. With proven success over more than 50 years, our OEM approved automotive products have been designed to achieve the longevity and durability performance essential to manufacturers in this market. All types of transportation vehicles have used our **Norbond**[®] Bonding Tapes and **Norseal**[®] Foam Sealing Tapes in the manufacturing of:

- Buses
- Class 8 trucks
- Horse and utility trailers
- Ambulances and fire trucks
- Truck cabs and bodies
- Intermodal containers

Saint-Gobain tapes make assembly easier, faster and more economical. Joints are stronger and more water tight with **Saint-Gobain** foam and tape products in place. Our engineers will work closely with you to determine the best solution for your bonding or sealing application.

Attachment Tapes

Products: Polyurethane Foam Attachment Tape, Acrylic Foam Attachment Tape

Function: Bonding of wall skin panels, roof bows, trims, moldings, emblems

Features: Quick-stick application, NVH benefits, color options for hiding in sight-line

Norbond Bonding Tapes have a long history of providing secure, long-lasting solutions for the transportation industry. Combining either a polyurethane or acrylic foam core with pressure sensitive acrylic adhesive, **Norbond** Tapes allow for tailored performance depending on specific application requirements. Bonding tapes offer many advantages to other fastening methods such as screws and rivets, including:

- Immediate bond strength for speed of assembly and handling time
- Durable foam core enables the distribution of stress across the entire bond line
- Fit and form providing fast application, and reducing clean up time

Norbond PUR Tapes offer reliable performance while also providing NVH benefits and a discrete black color that hides from the sight line. **Norbond** Acrylic Tapes offer higher elongation capability, crucial for areas that experience thermal expansion and high differential movement.

- **Norbond** V2800 has a black polyurethane foam core that features high conformability to help with adhesive-to-surface contact. The color allows the product to hide in the sight-line, creating a pleasing visual aesthetic, while the pressure sensitive acrylic adhesive provides secure long term bonding performance. Suitable for emblem attachment, roof bow attachment, and general bonding applications with parts less than 3 feet in length.
- **Norbond** A7600 features a gray acrylic foam core that allows for greater elongation capability. A specially formulated pressure sensitive adhesive exhibits strong quick-stick characteristics and high adhesion capability in a short term period, speeding up assembly. Best suited for interior and exterior trailer skin bonding.
- **Norbond** A7450 (white) and A7350 (gray) feature an acrylic foam core that offer high ultimate peel and tensile adhesion performance. Best used in applications where stresses may be elevated due to the presence of additional treatments, such as welds or thicker gauge materials.

Common Attachment and Sealing Tape Applications

1 | Norbond Bonding Tapes

2 | Norseal Sealing Tapes

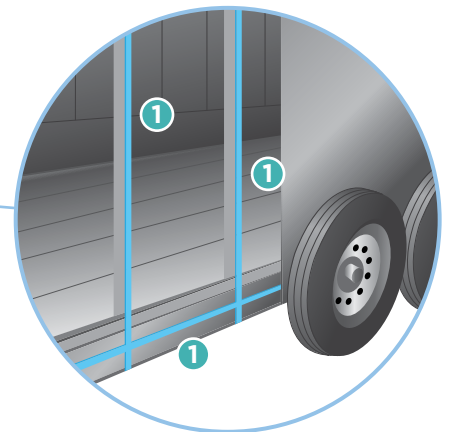
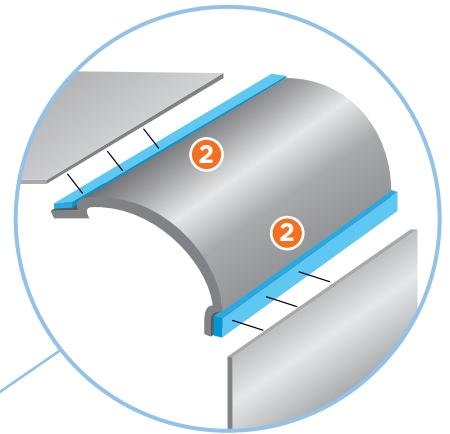
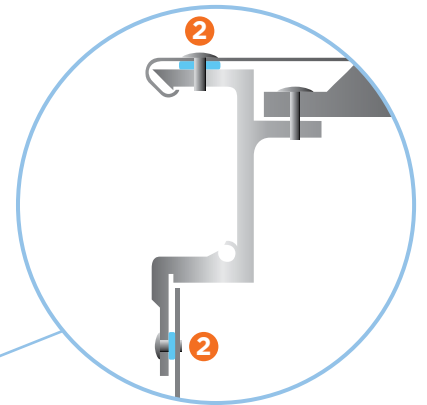
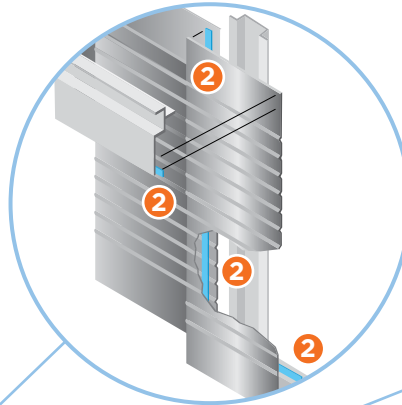

Sealing Tapes

Products: PVC Foam Tape, PUR Foam Tape

Function: Sealing foam tape

Features: Swirl-free properties; wide range of firmness options; aggressive adhesive for quick-stick; seals out air, dust and moisture

Norseal is the foam sealant standard for many manufacturers in the transportation industry. Made of closed-cell compressible foam with pressure sensitive adhesive, **Norseal** Foam Sealing Tapes are designed to seal against water, dirt, and air when compressed 30% under extreme conditions. Because of the tape's aggressive adhesive, application is quick and accurate. Other advantages include:

- No special tools needed to apply
- No curing required
- Won't ooze or squeeze out of the joint
- Won't dry out, drip, crack or become brittle

Norseal PVC Foam Tapes, offered with differing levels of firmness, provide balanced properties with weathering capability you can rely on. The **Norseal** PUR Foam Tapes accommodate the elevated temperatures typical with paint cycles. **Norseal** remains flexible through the hottest desert regions and the coldest mountain passes, enabling travel through all global climates. Whether applied to the riveted roof top rail seam on a 53-foot trailer or the overlap seam on a class 8 truck cab, **Norseal** Foam Sealing Tapes will protect against the weather elements.

- **Norseal** V620 is a medium firmness foam tape that provides enhanced tear and tensile strength properties. Users find this valuable when trimming exposed tape in areas of the vehicle with special aesthetic considerations.
- **Norseal** V710 is a medium firmness foam tape with swirl-free properties that make it ideal to accommodate fasteners without twisting or distorting the foam. This tape is designed for use in side lap seams.
- **Norseal** V730 is a soft foam tape that is ideal for sealing thin gauge materials and larger gaps. The softer foam minimizes the distortion of the assembly and minimizes the number of fasteners required to compress the foam.
- **Norseal** V740 is a medium firmness foam tape with balanced properties for multi-use and is economically positioned.
- **Norseal** V760 is a firm high density foam tape with abrasion resistant properties, making it the best option for sealing thicker panels seams with larger fasteners.
- **Norseal** V980/V990 is a firm tape with pressure sensitive adhesive on both sides. The additional adhesive acts as a secondary barrier in the seal and aids in assembly by minimizing the amount of clamps required. A common application is sealing top and bottom rails.
- **Norseal** V4000H is a very firm polyurethane foam tape. It is able to withstand elevated temperatures that are associated with paint cycles.

Attachment Tape Material Selection Guide

Backing Material	Product Code	Color	Thickness in (mm)	Adhesive Configuration/ Type	90° Peel Adhesion (stainless steel) lb/in (N/cm)	Tensile Adhesion psi (kPa)	Dynamic Shear Adhesion psi (kPa)	Common Application
PUR	V2800	Black	0.030, 0.045, 0.062, 0.090, 0.120 (0.8, 1.2, 1.6, 2.3, 3.0)	C2S/ Acrylic PSA	12 (21)	100 (689)	120 (827)	Emblem attachment, roof bow attachment
Acrylic	A7600	Gray	0.043, 0.062 (1.1, 1.6)	C2S/ Acrylic PSA	22 (39)	83 (572)	79 (545)	Interior and exterior trailer skin bonding
Acrylic	A7450	White	0.043 (1.1)	C2S/ Acrylic PSA	30 (53)	142 (979)	84 (579)	In combination with additional treatments, such as welds or thicker gauge materials
	A7350	Gray						

Sealing Tape Material Selection Guide

Backing Material	Product Code	Color	Thickness in (mm)	Adhesive Configuration/ Type	Density lb/ft ³ (kg/m ³)	Force to Compress @ 25% psi (kPa)	Compression Deflection @ 25% psi (kPa)	Common Application
PVC	V620	Gray	0.062, 0.094 (1.6, 2.4)	CIS/Acrylic Aqueous	10 (160)	8 (55)	5 (35)	Truck body and trailer seams with critical aesthetics
PVC	V710	Gray	0.062, 0.125, 0.188, 0.25, 0.375 (1.6, 3.2, 4.8, 6.4, 9.5)	CIS/Acrylic Aqueous	10 (160)	4.7 (32.4)	1.9 (13.1)	Panel side lap seams
PVC	V730	Gray	0.125, 0.188, 0.25, 0.375, 0.5, 0.625, 0.75 (3.2, 4.8, 6.4, 9.5, 12.7, 15.9, 19)	CIS/Acrylic Aqueous	6 (96)	2.0 (13.8)	1.1 (7.6)	Floor to bottom rail
PVC	V740	Gray, Black	0.062, 0.125, 0.188, 0.25, 0.375 (1.6, 3.2, 4.8, 6.4, 9.5)	CIS/Acrylic Aqueous	9 (144)	3.5 (24.1)	2.0 (13.8)	Panel side lap seams
PVC	V760	Gray	0.062, 0.125, 0.188, 0.25 (1.6, 3.2, 4.8, 6.4)	CIS/Acrylic Aqueous	15 (240)	7.2 (49.6)	3.4 (23.4)	Thick gauge panel side lap seams
PVC	V980/V990	Black, Gray, White	0.032, 0.062, 0.125, 0.188, 0.25 (0.8, 1.6, 3.2, 4.8, 6.4)	CIS/Acrylic Solvent	15 (240)	8.9 (61)	6.6 (46)	Sealing top and bottom rails and any critical water seal joints
PUR	V4000H	Black	0.030, 0.062 (0.8, 1.6)	CIS/Acrylic Solvent	31 (497)	13 (89.7)	10 (69)	Truck body seams

Your Partner in Custom Tape Solutions

A custom tape solution can pay for itself many times over thanks to the process and product improvements it can provide. Tape development engineers will work with partners to design an economical but highly effective tape product.

Even with endless permutations of industrial tapes available there is only one company that can deliver a custom-made tape with optimal adhesive, the perfect backing materials, seamless process integration and superb performance.

To learn more about how **Saint-Gobain** can help solve tape and materials engineering challenges, call us or visit us online.

Distributed by:

Scan to visit our website:



Saint-Gobain Tape Solutions

North America | South America | Europe | Asia

For a full list of locations, please visit tapesolutions.saint-gobain.com/contact-us

IMPORTANT: It is the user's responsibility to ensure the suitability and safety of Saint-Gobain products for all intended uses and that the materials to be used comply with all applicable regulatory requirements. Saint-Gobain assumes no responsibility for any product failures that occur due to misuse of the materials it provides arising out of the design, fabrication or application of the products into which the materials are incorporated.

WARRANTY: For a period of 6 months, Saint-Gobain warrants this product(s) to be free from defects in manufacturing. The only obligation under any applicable product warranty will be to replace any portion proving defective, or at our option, to refund the purchase price thereof. SAINT-GOBAIN DISCLAIMS ALL IMPLIED WARRANTIES OF MERCHANTABILITY AND FITNESS FOR A PARTICULAR PURPOSE.

Form #1623 | © Saint-Gobain July 2020 | **Norbond** and **Norseal** are trademarks of Saint-Gobain.